

# MV-CL084-90CM

8192 P Camera Link Line Scan Camera



GEN<i>i>CAM



## Introduction

MV-CL084-90CM camera adopts the Time Delay Integration (TDI) technology and uses Camera Link interface to transmit image, and its max. line rate can reach 100 kHz. It supports different image modes and is applicable to printing, metallurgy, food, transportation, logistics, etc.

## Key Feature

- Supports configuration modes of Base, Medium, Full and 80-bit via the Camera Link interface.
- Supports TDI function to select different image modes.
- Supports exposure time and gain adjustment, PRNUC correction, LUT, Gamma correction, etc.
- Compact design and flexible installation.
- Compatible with Camera Link Protocol and GenCam Standard.

## Dimension

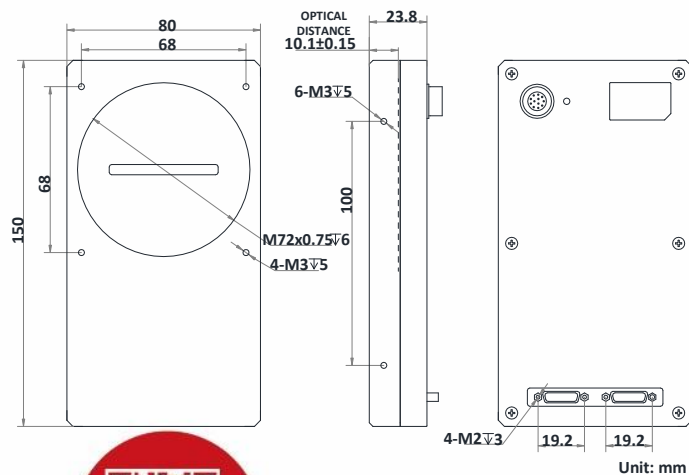

## Available Model

MV-CL084-90CM

## Applicable Industry

Printing, metallurgy, food, logistics, transportation, material sorting, pharmaceutical manufacturing, etc.

## Sensor Quantum Efficiency

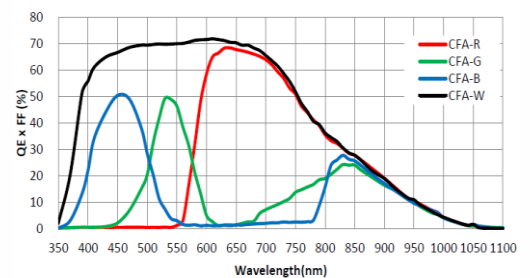

# Specification

<b>Model</b>	<b>MV-CL084-90CM</b>
<b>Camera</b>	
<b>Sensor type</b>	CMOS
<b>Pixel size</b>	5 $\mu$ m
<b>Resolution</b>	8192 $\times$ 4
<b>Image mode</b>	Supports 1-line, 2-TDI, 4-TDI
<b>Max. line rate</b>	20 kHz (Base), 40 kHz (Medium), 80 kHz (Full), 100 kHz (80-bit)
<b>Configuration mode</b>	Base, Medium, Full, 80-bit
<b>Tap geometry</b>	1X2, 1X4, 1X8, 1X10
<b>Tap number</b>	2 Taps, 4 Taps, 8 Taps, 10 Taps
<b>Pixel clock</b>	40 MHz, 60 MHz, 70 MHz, 85 MHz
<b>Dynamic range</b>	62 dB
<b>SNR</b>	42 dB
<b>Gain</b>	Supports 2.7 $\times$ , 3.0 $\times$ , 3.5 $\times$ , 4.6 $\times$ , 6.2 $\times$
<b>Exposure time</b>	3 $\mu$ s to 10 ms
<b>Exposure mode</b>	Off/ Once/ Continuous exposure mode; supports fixed exposure time, trigger-width exposure
<b>Mono/color</b>	Mono
<b>Pixel format</b>	Mono 8/10/12
<b>Binning</b>	Supports 1 $\times$ 1, 1 $\times$ 2, 1 $\times$ 4, 2 $\times$ 1, 2 $\times$ 2, 2 $\times$ 4, 4 $\times$ 1, 4 $\times$ 2, 4 $\times$ 4
<b>Reverse image</b>	Supports horizontal reverse image output
<b>Trigger mode</b>	External trigger, internal trigger
<b>External trigger mode</b>	Line trigger, frame trigger, line + frame trigger
<b>Electrical features</b>	
<b>Data interface</b>	Camera Link; USB interface for updating firmware
<b>Digital I/O</b>	12-pin Hirose connector provides power and I/O, including differential input $\times$ 2 (Line 0, Line 3), differential output $\times$ 2 (Line 1, Line 4). Camera Link provides I/O (CC1/CC2/CC3/CC4)
<b>Power supply</b>	12 VDC to 24 VDC
<b>Power consumption</b>	Typ. 12.3 W@12 VDC
<b>Mechanical</b>	
<b>Lens mount</b>	M72*0.75, optical back focal length: 10.1 mm (0.4"), applicable to F-mount via lens adapter
<b>Dimension</b>	150 mm $\times$ 80 mm $\times$ 23.8 mm (5.9" $\times$ 3.1" $\times$ 0.9")
<b>Weight</b>	Approx. 400 g (0.9 lb.)
<b>Ingress protection</b>	IP40 (under proper lens installation and wiring)
<b>Temperature</b>	Working temperature: 0 $^{\circ}$ C to 50 $^{\circ}$ C (32 $^{\circ}$ F to 122 $^{\circ}$ F) Storage temperature: -30 $^{\circ}$ C to 70 $^{\circ}$ C (-22 $^{\circ}$ F to 158 $^{\circ}$ F)
<b>Humidity</b>	20% to 80% RH, non-condensing
<b>General</b>	
<b>Client software</b>	MVS and frame grabber software meeting with Camera Link Protocol
<b>Operating system</b>	32/64-bit Windows XP/7/10
<b>Compatibility</b>	Camera Link V1.2, GenICam
<b>Certification</b>	CE, FCC, RoHS, KC

## HIKROBOT

Hangzhou Hikrobot Technology Co., Ltd.

No.399 Danfeng Road, Binjiang District, Hangzhou 310051, China.

en.hikrobotics.com

Copyright Hikrobot

Hangzhou Hikrobot Technology Co., Ltd. All Rights Reserved. Hangzhou Hikrobot Technology does not tolerate any infringement. Any organization or individual may not imitate or reproduce in whole or in part of the content. The data herein is based on Hikrobot's internal evaluation. Actual data may vary depending on specific configuration and operating condition. The information herein is subject to change without notice. All the content has been checked conscientiously. Nevertheless, Hikrobot shall not be liable to damages resulting from errors, inconsistencies or omissions.